



# MILKING POINT MANAGEMENT LEVEL 3

## iNTELSKAN PLUS with ACR



### iNTELSKAN LEVEL 3

iNTELSKAN PLUS level 3 improves productivity and efficiency by reducing operator workload at milking time. In most systems labour input can be reduced and with the bail restraint option on rotaries one person can milk alone.

The cluster is automatically removed from the cow using the iHDR100 Ram. The system is suitable for herringbone and rotary installations. All level 1 & 2 options are supplied as standard and you can expand this system at any time.

### KEY FEATURES

- Reduces operator workload
- Eliminates over milking
- Incorporates all level 1 & 2 features
- Smart automation features such as cluster drop on rotaries and bail restraints are optional
- Yield flow & milking time display
- Data to iTRAC (optional)

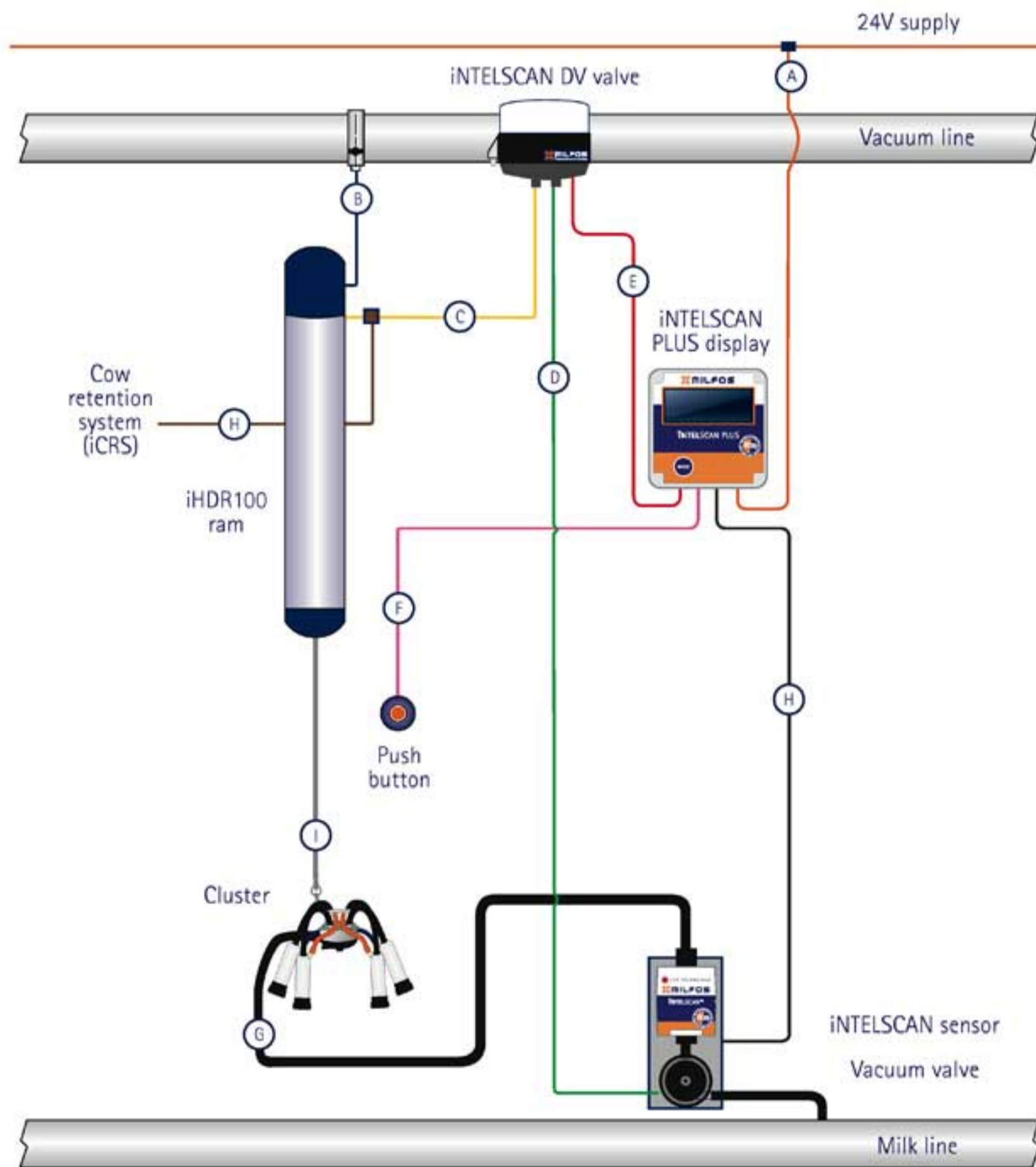

- |  |                                  |                          |
|--|----------------------------------|--------------------------|
| <b>A</b> Power supply 24V              | <b>D</b> Signal tube             | <b>G</b> 19mm milk tube  |
| <b>B</b> Vacuum supply                 | <b>E</b> iNTELSKAN DV control    | <b>H</b> Sensor cable    |
| <b>C</b> iHDR100 control vacuum signal | <b>F</b> Push button control 24V | <b>I</b> Retraction cord |