



# INTELSCAN PLUS with Dataflow for Swing Over Herringbones



iNTELARM and iARM are designed specifically for INTELSCAN and iDATAFLOW automation so that you get a high level of milking performance. Once you have selected from levels 1 -4 of INTELSCAN Milking Point Hardware you can then select your parlour automation requirements. Data Terminals, LCD Message Screens, Sorting and Weighing options are just a few of the iDATAFLOW modules that link to your INTELSCAN system. If you are not purchasing the full suite of automation modules we recommend that you make adequate provision for the future.

## iDATAFLOW MODULES FOR INTELSCAN

- Select your INTELSCAN Milking Point options 1-4 (see [7.3.10](#))
- iNTELARM and iARM solutions are provided (see [7.4.16](#))
- Details on iDATAFLOW modules are included in the Automation section
- Details of suitable layouts with a guide to locating the iDATAFLOW modules are included in the Stalling and Milking sections
- iDATAFLOW and INTELSCAN are suitable for new and existing milking parlours
- Think ahead to 'Future Proof' your operation

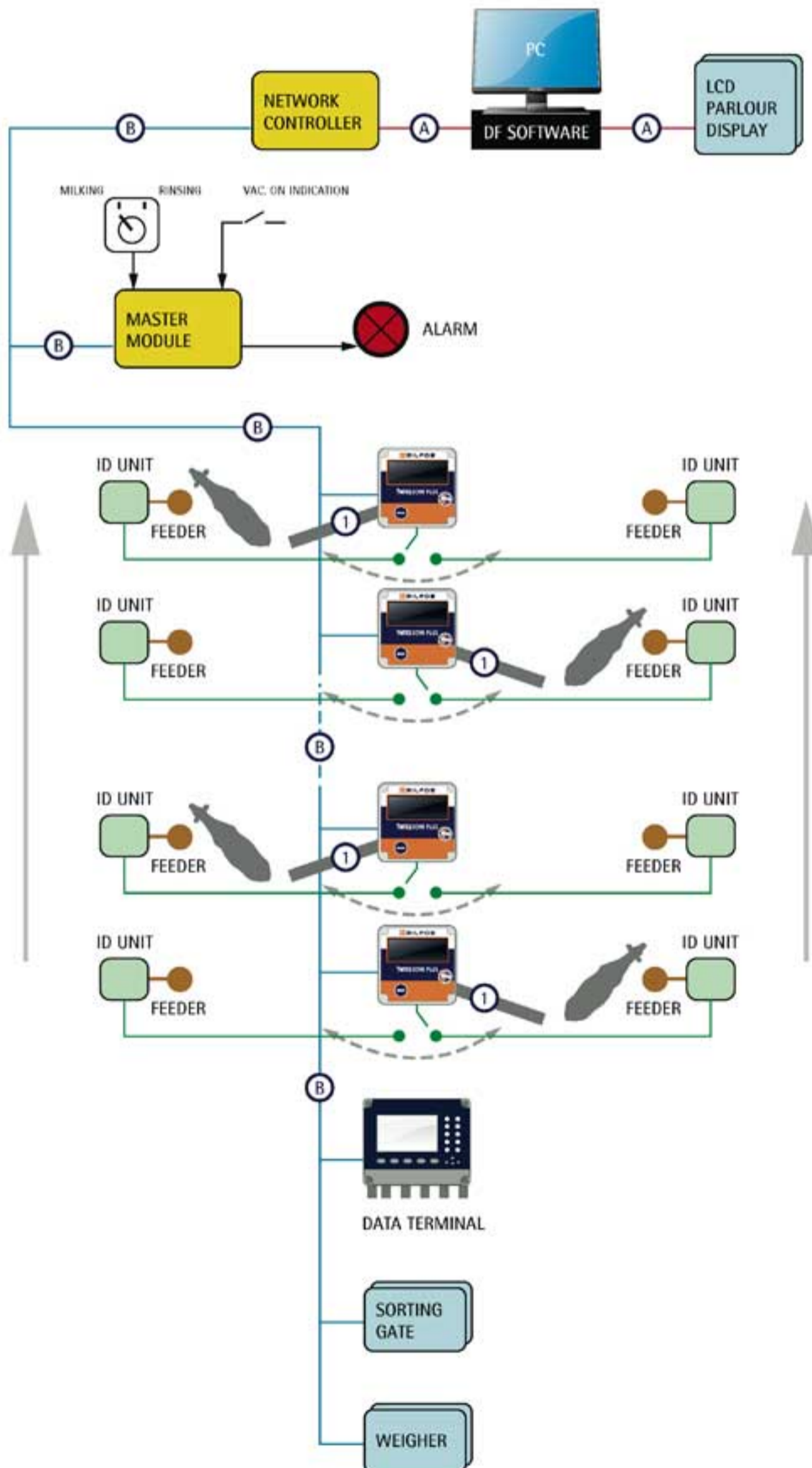

| REF | DESCRIPTION      |
|-----|------------------|
| 1   | iARM or iNTELARM |
| A   | RS232 Network    |
| B   | RS485 Network    |

