



iARM & iNTELARM

The iNTELARM product line sets new standards in swing over milking technology. With iNTELARM you not only get high dependability you also get enhanced milking performance.

Cluster alignment is perfect every time ensuring a clean and even milk out of the cow. The specially designed and developed iNTELARM guides the cluster from side to side. Automation products are easily fitted to both iARM and the top-of-the-line iNTELARM which increases the operators productivity at milking time without effecting the natural efficiency of the swing over type system. You can build your system from a base level to a fully equipped arm with automated take off, milk metering and control switch.

Innovative design and attention to engineering excellence sets iNTELARM apart.

iARM and iNTELARM Benefits

- Removal of the standard droppers opens up the pit and working area for the milking operators
- Promotes the natural work routine efficiency that you get with swing over technology
- Cluster alignment is perfect every time
- Short milk tubes from the cluster to the arm eliminate cluster drag
- Future proof your parlour with 'bolt on' automation options

Integrated Design

- Fits to sturdy double carriage rail system
- Compatible with new and existing parlours
- Modular mounting system allows adjustment in height and milk line nozzle spacing

iARM KEY DESIGN PARAMETERS

- Zinc plated mild steel bracket
- Laser cut and folded to exacting dimensions
- Rubber milk and air hoses located using innovative milk & air tube clip design (see )
- Precision bearings with lubrication point for smooth operation and long life

iNTELARM KEY DESIGN PARAMETERS

- Stainless steel construction
- Laser cut and folded to exacting dimensions
- Integral stainless steel milk and air tube cartridge for easy replacement of rubberware
- Precision bearings with lubrication point for smooth operation and long life



iNTELARM WITH INTELSCAN PLUS LEVEL 2 - SAFE MILKING WITH PULSATION ARREST



iARM

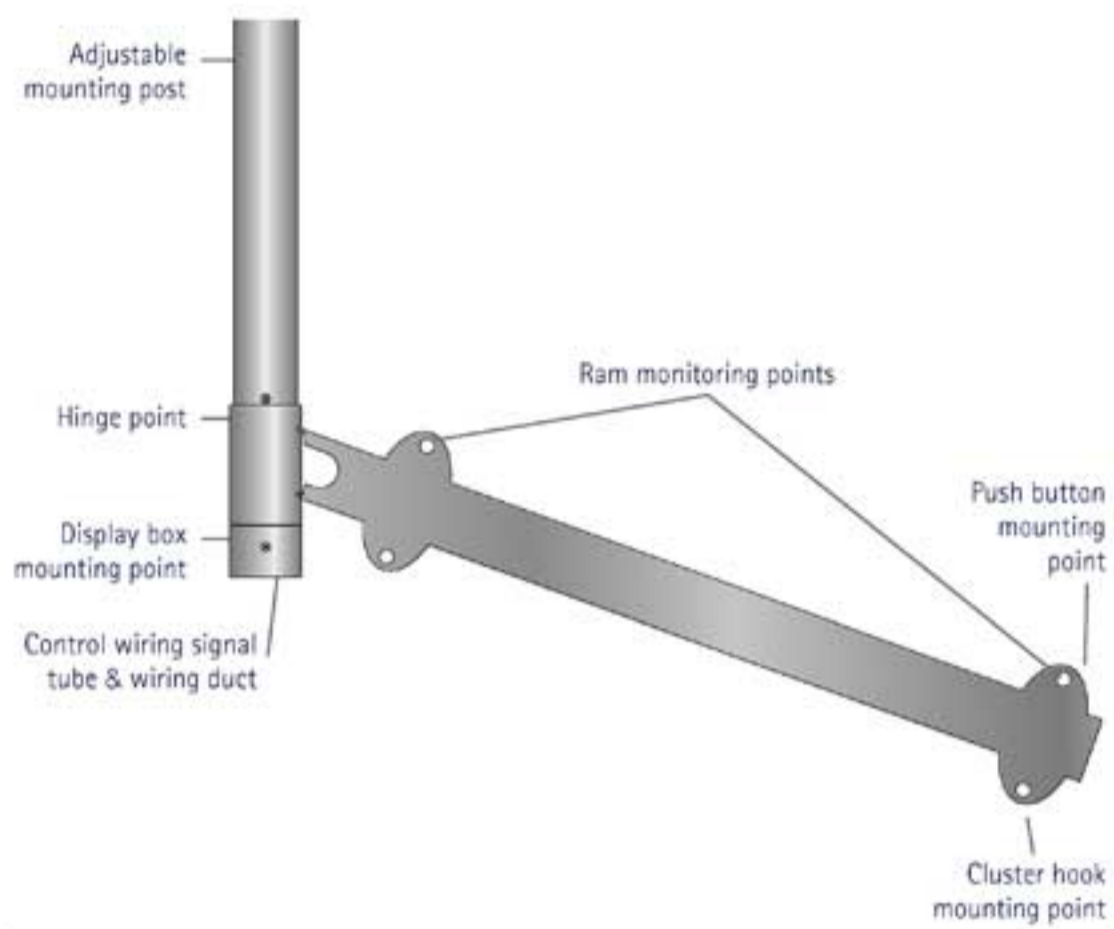

iNTELARM

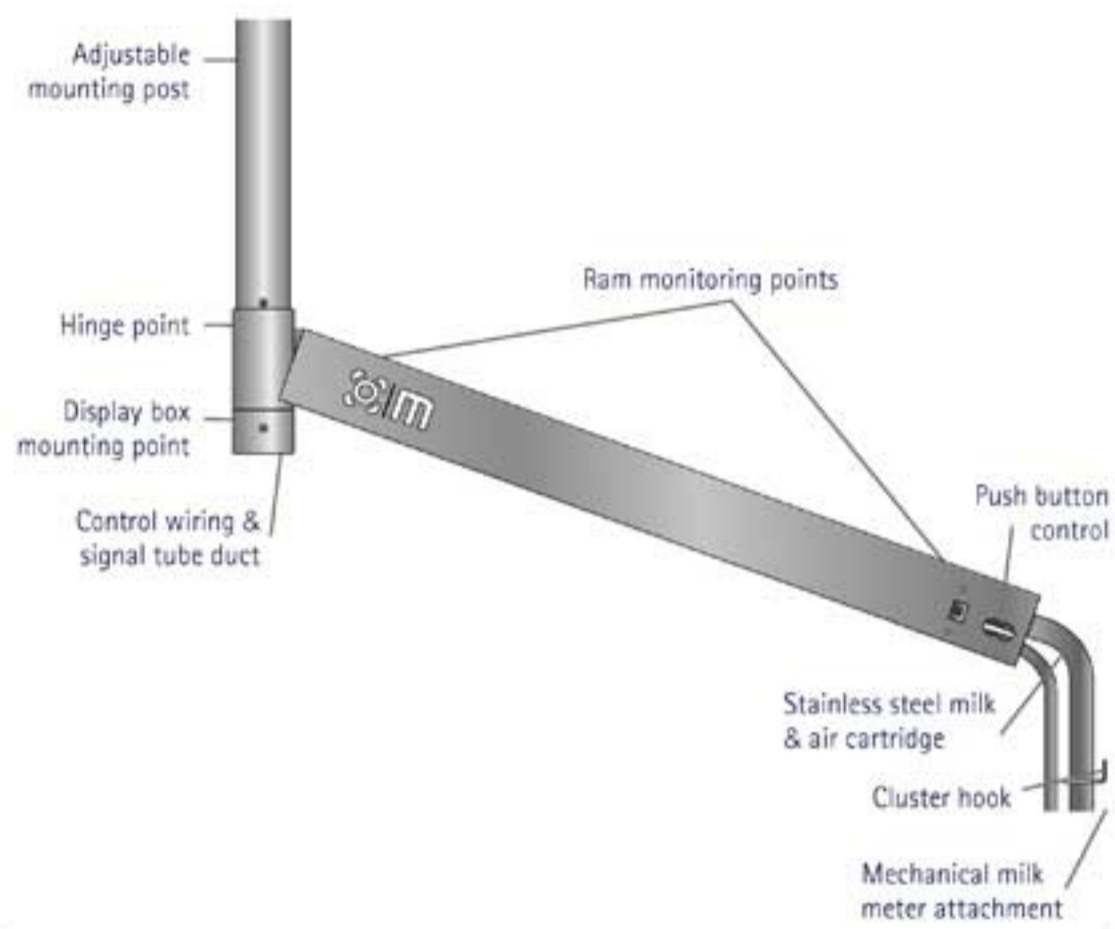

iNTELARM USED ON HERD TEST DAY WITH MECHANICAL MILK METERS

iNTELARM parked for washing



iNTELARM with iCR installed



iNTELARM showing iNTELSAN display box



Perfect cluster alignment with iNTELARM

